



## High Sparkle Glass and Dishwashing Experience

The new, easy to use, technology used in the Optima 500 guides you through the functions and systems of the machine. The soft-touch panel with multi-colour start key and read out display keeps you informed of the machine's status. Any faults are immediately shown on the screen via the self diagnostic program. The innovative rinse system combined with the choice of 6 programs guarantees that the Optima 500 meets the highest levels of sanitation.

### Wash Programs

The Optima 500 has 6 programs to choose from: two wash/rinse programs (standard & long); two special glass washing programs (at 70°C) and two "clean" programs. During a "clean" cycle all the wash tank water is refreshed with clean water. This is ideal when switching between heavily soiled plate washing and glass washing or for infection control purposes in hospital wards. At the end of the wash cycle the start key flashes between blue and green making it easy to identify during peak periods.

### RHIMA Intensive Final Rinse System

The unique final rinse system is totally independent of mains pressure and temperature. With traditional systems incoming water forces the 82°C water in the booster tank into the nozzles. The result of this method is that towards the end of the rinse cycle the temperature drops because incoming temperature mixes with booster temperature. The new Rhima final rinse does not allow any water to enter the booster heater until the end of the rinse cycle. This guarantees a constant minimum 82°C final rinse which is essential for meeting HACCP guidelines.

### Overall

The Optima 500 can be complemented with compartmentalised washing racks for glass washing.

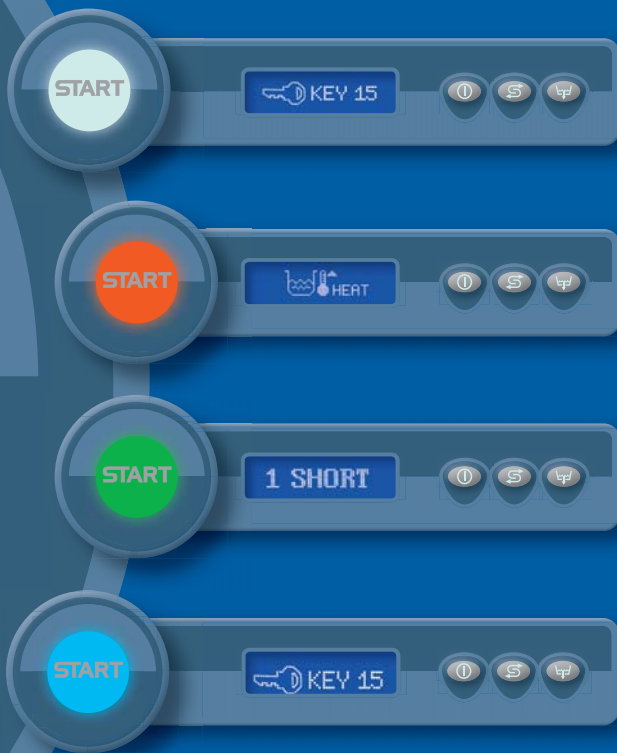

### Optimal ease of use with the innovative multi-colour start function & peace of mind maintenance.

The soft-touch panel with multi-colour key will lead you in an easy and intuitive way through the operation of your machine. The LCD display will clearly indicate temperatures, cycles and functions:

|       |                 |
|-------|-----------------|
| WHITE | : Settings      |
| RED   | : Pre-heating   |
| GREEN | : Ready for use |
| BLUE  | : Cycle running |

Each Optima has self diagnostics, an innovative the machine final rinse, six programs and high quality sanitation process. When you buy an Optima system we not only guarantee good results, we also guarantee peace of mind maintenance with our Optima Support Service.



## OPTIMA 500 - SPECIFICATIONS

### TECHNICAL DATA

|                                   |                              |
|-----------------------------------|------------------------------|
| Racks per hour (qty) <sup>1</sup> | 12 - 60                      |
| Cycle times <sup>2</sup>          | 75-300 sec                   |
| Power connection                  | 240V - 50Hz or 415V - 50Hz   |
| Wash pump (W)                     | 650                          |
| Rinse pump (W)                    | 250                          |
| Booster heater (W)                | 2950 or 6000                 |
| Tank heater (W)                   | 1100                         |
| Max load                          | 3600W(15Amp)or6650W(3x10Amp) |
| Wash tank capacity normal         | 10 ltrs                      |
| Wash tank capacity clean cycle    | 7 ltrs                       |
| Booster heater capacity           | 14 ltrs                      |
| Water consumption normal          | 2.5 ltr/cycle                |
| Water consumption clean           | 7 ltr/cycle                  |
| Rack size                         | 500x500                      |
| Max door height                   | 340mm                        |
| Water connection                  | 3/4" BSP F hose supplied     |
| Water connection temperature      | max. 65°C                    |
| Drain                             | pump out max 1 mtr           |

<sup>1</sup> depends on chosen program and inlet water temperature

<sup>2</sup> depends on chosen program

### UNIQUE FEATURES OF THE RHIMA OPTIMA 500:

- Specifically suited for connection to Rhima's RO 120 High Sparkle System
- Many standard inclusions such as; detergent pump, rinse aid injector, CIP (cleaning in place) program, drain pump, break tank, full thermal and acoustic insulation
- The mochrome final rinse
- Self cleaning wash jets
- Read out display with language selection
- Cycle run time indicator
- Six programs including two "clean" cycles
- Intensive final rinse
- Deep formed and rounded tank construction
- Energy saving
- The most stop

## OPTIMA 500 - DIMENSIONS

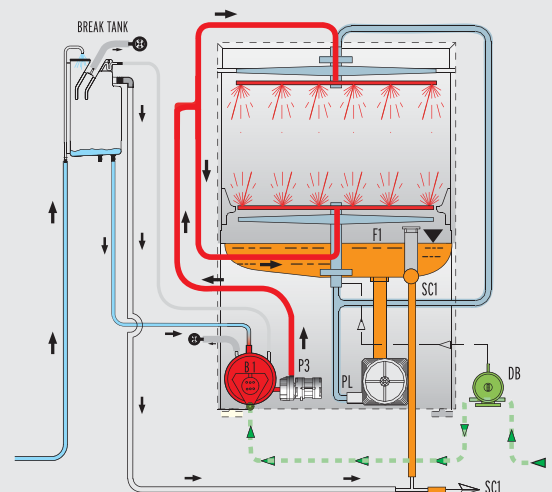
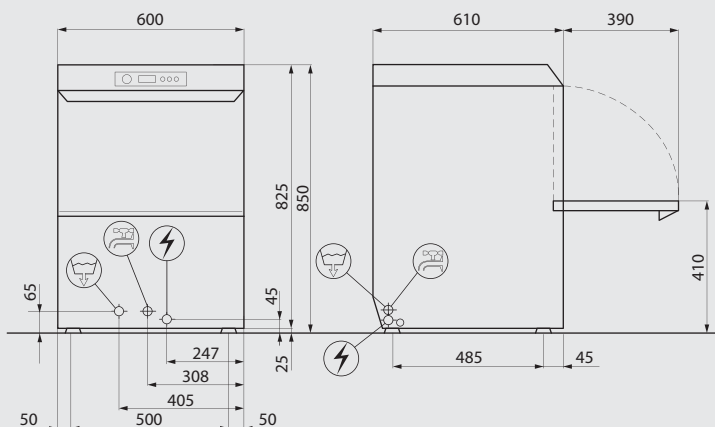

*The Rhima intensive rinse system.*

**Rhima Australia Pty Ltd**  
AEN 63 007 242 604

72-74 Woodlands Drive Brea side 3195  
Tel: 03 8586 5444 Fax: 03 8586 5454  
website: [www.rhima.com.au](http://www.rhima.com.au)